

How to offer the LONG MANDALA

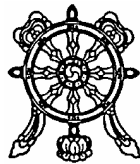

Produced by Langri Tangpa Centre Inc.

© *Langri Tangpa Centre Inc. 2007*

535 Old Cleveland Road

Camp Hill QLD 4152

ABN: 49 770 532 185

tel: (07) 3398 3310

fax: (07) 3398 3314

email: info@langritangpa.org.au

website: www.langritangpa.org.au

This booklet prepared by Miffi Maxmillion. All mistakes or omissions due entirely to her.

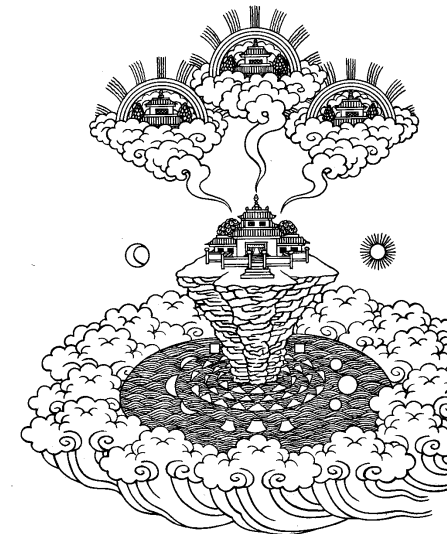

**Produced by
Langri Tangpa Centre
2007**

TARA MANDALA OF 23 HEAPS

OM vajra bhumi AH HUM

Wang.chen ser.gyi sa.zhi

OM vajra rekhe AH HUM

chi chag.ri kor.yug.gi kor.wai

1 u.su ri gyäl.po ri.rab

2 shar lu.pag.po

3 lho dzam.bu.ling

4 nub ba.lang.chö

5 jang dra.mi.nyen

6&7 lu.dang lu.pag

8&9 nga.yab.dang nga.yab.zhen

10&11 yo.dang dang.lam chog.dro

12 dra.mi.nyan.dang

13 dra.mi.nyan gyi.da

14 Shar.du lang.po rin.po.che

15 Lhor.kyin.dag rin.po.che

16 Nub.tu.ta rin.po.che

17 Jang.du tsun.mo rin.po.che

18 Shar.lhor mag.pon rin.po.che

19 Lho.nub.tu khor.lo rin.po.che

20 Nub.jang.du nor.bu rin.po.che

21 Jang.shar du.ter chen.poi bum.pa

22 Nang.gi shar.du nyi.ma

23 nub.tu da.wa

24 Dag.zhan lu.nag yi.sum

long.cho dus.sum ge.tsog cha
Rin.chen mandala zang.po

kun.zang cho.pai tsog.cha pa

Lo.yi lang.ne la.ma yi.dam

kon.chog sum.la bul

Thug.jei wang.gi zhe.ne dag.la

jin.gyi lab.tu sol

OM vajra ground AH HUM, mighty

golden ground. OM vajra fence AH

HUM, the iron fence around the

edge. In the centre is Mount Meru,
the king of Mountains,

In the east the continent of Lupapo,

In the south Dzambuling,

In the west Balangcho,

In the north Draminyan.

In the east are the sub-continents Lu

and Lupang, in the south Ngayab and

Nyayab-zhan, in the west Yodan and

Lamchog-dro, in the north

Draminyan and Draminyan-gyida.

In the east the precious elephant,

the south the precious housekeeper,

the west the precious horse,

the north the precious queen.

In the southeast the precious general,

The southwest the precious wheel,

The northwest the precious jewel,

The northeast the great treasure vase.

In the east, the sun,

In the west, the moon.

My own and other's body, speech
and mind, wealth and virtues of the
three times, this pure precious
mandala and a mass of

Samantabhadra offerings, I mentally
offer to my guru-yidam and the Three
Precious Ones. Please accept them
through compassion and bestow your
inspiration.

DIAGRAM OF THE MANDALA WORLD SYSTEM

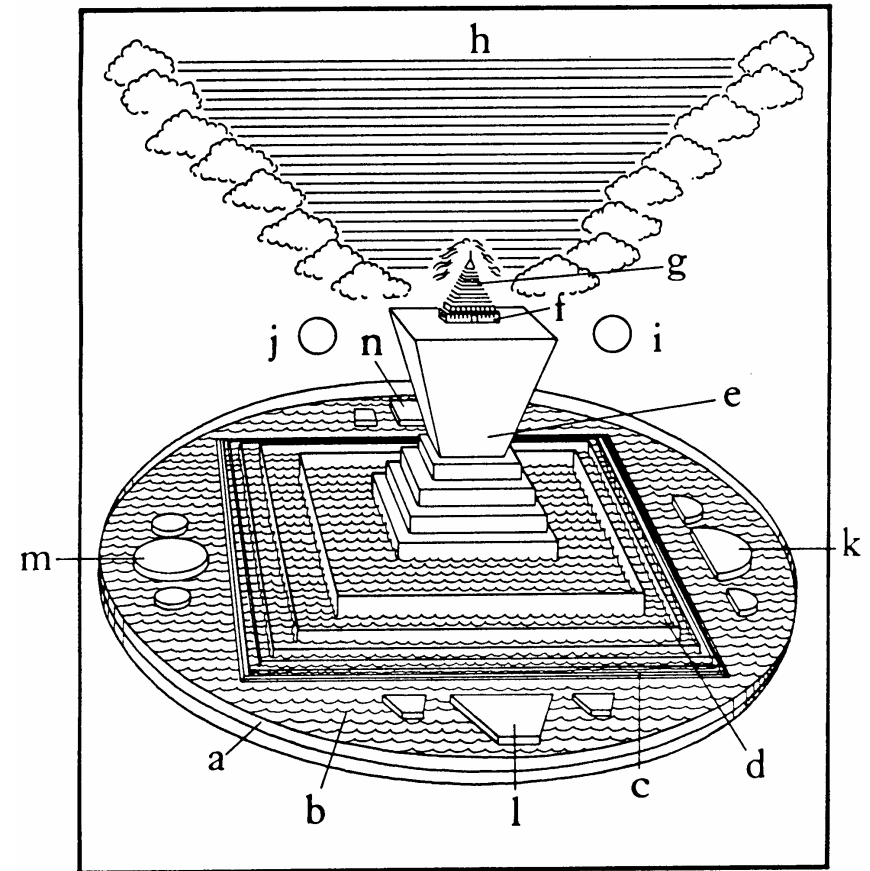

Fig. 2. Traditional depiction of the main features of the Ideal Universe.

a. iron mountain

b. ocean

c. seven rings of mountains

d. seven lakes

e. Mt. Meru

f. city of Vishnu

g. Indra's palace

h. deva-realms

i. sun

j. moon

k. Videha and satellites

l. Jambudvipa and satellites

m. Godaniya and satellites

n. Uttara-Kuru and satellites

MANDALA OF 37 HEAPS

PREPARING THE BASE:

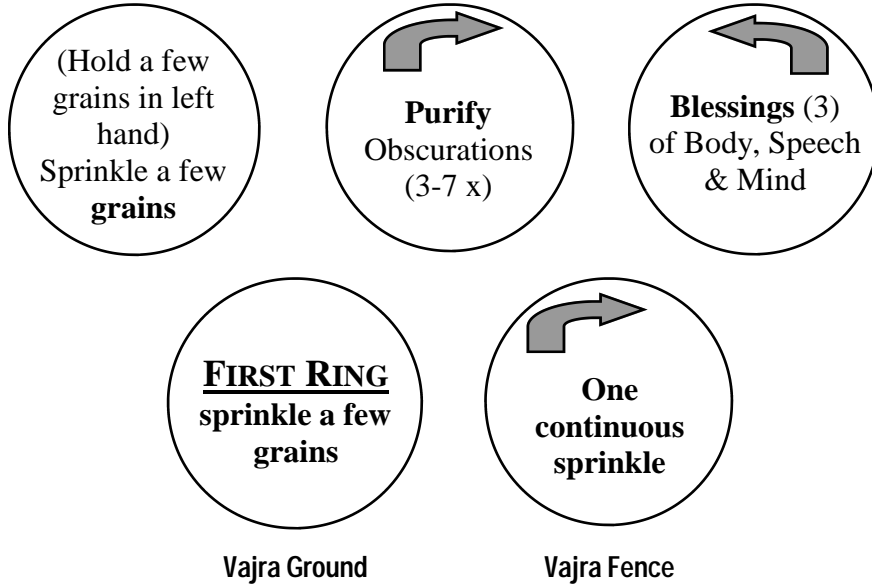

FIRST RING:

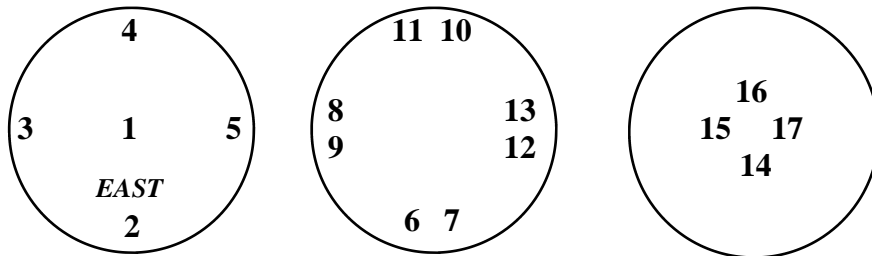

Four Continents
 E) Noble Figure
 S) Jambu Island
 W) Enjoyment of Cattle
 N) Kuru Sound

Eight Sub-Continents

Four Precious Things
 14) Mountain of Jewels
 15) Wish-granting Tree
 16) Wish-fulfilling Cow
 17) Unploughed Harvest

MANDALA OF 23 HEAPS

PREPARING THE BASE:

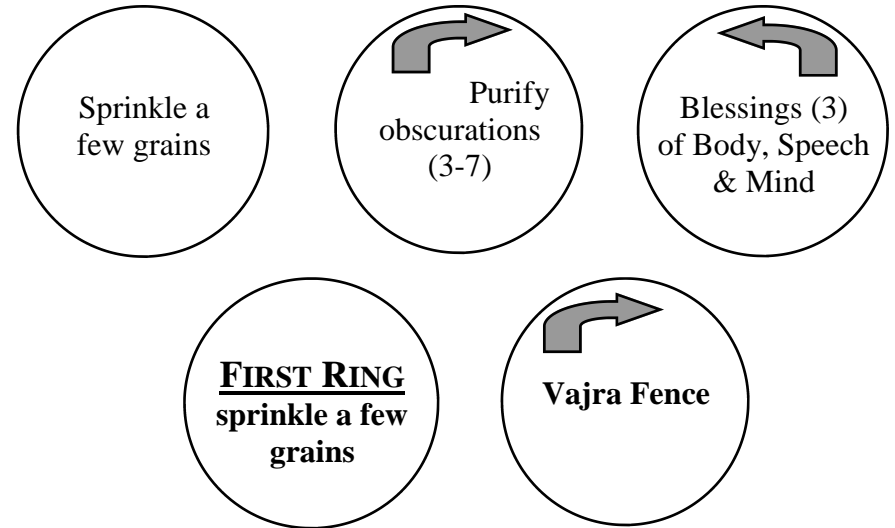

FIRST RING:

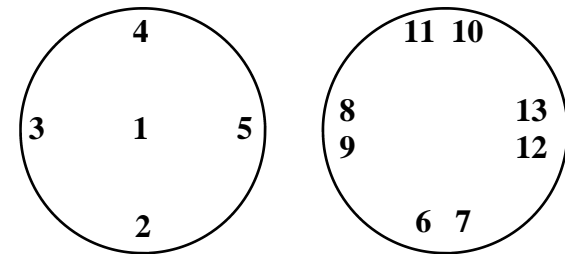

TOP RING:

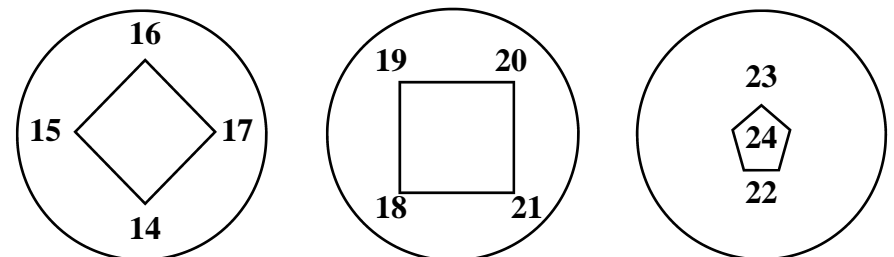

MANDALA OF 7 HEAPS

PREPARING THE BASE:

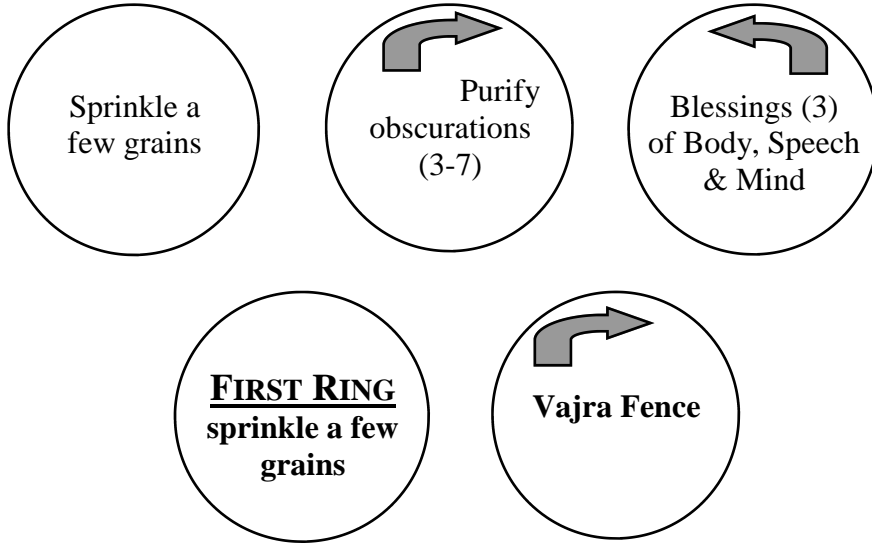

TOP RING:

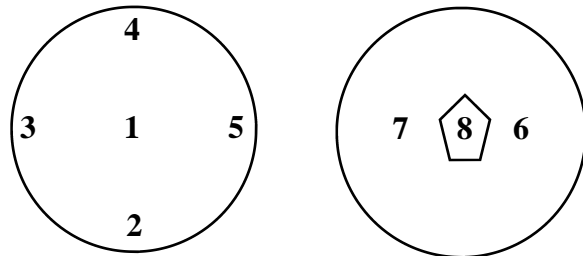

SECOND RING:

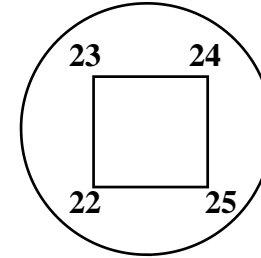
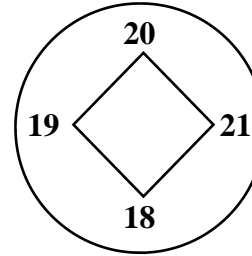

7 Precious Emblems

- 1) Wheel
 - 2) Jewel
 - 3) Queen
 - 4) Minister
 - 5) Elephant
 - 6) Horse
 - 7) General
- ...& Precious Vase

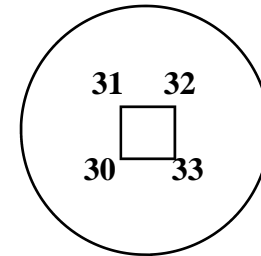
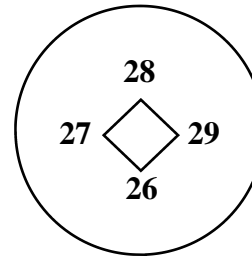

8 Goddesses

- 1) Beauty
- 2) Garlands
- 3) Song
- 4) Dance
- 5) Flowers
- 6) Incense
- 7) Light
- 8) Perfume

TOP RING:

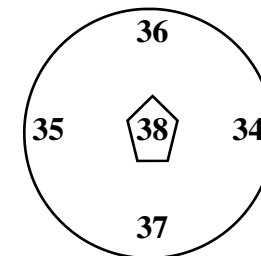

- 34) Sun
- 35) Moon
- 36) Umbrella
- 37) Victory Banner
- 38) All the Riches of Gods & Humans

TARA MANDALA OF 37 HEAPS

OM vajra bhumi AH HUM

Wang.chen ser.gyi sa.zhi

OM vajra rekhe AH HUM

chi chag.ri kor.yug.gi

- 1 kor.wai u.su
ri gyäl.po ri.rab
- 2 shar lu.pag.po
- 3 lho dzam.bu.ling
- 4 nub ba.lang.chö
- 5 jang dra.mi.nyen

- 6&7 lu.dang lu.pag
- 8&9 nga.yab.dang nga.yab.zhen
- 10&11 yo.dang dang.lam chog.dro
- 12 dra.mi.nyan.dang
- 13 dra.mi.nyan gyi.da

- 14 rin.po.che ri.wo
- 15 pag sam.gyi shing
- 16 do.jö ba
- 17 ma.mo.pa.yi lo.tog

- 18 kor.lo rin.po.che
- 19 nor.bu rin.po.che
- 20 tsun.mo rin.po.che
- 21 lön.po rin.po.che
- 22 lang.po rin.po.che
- 23 ta.chog rin.po.che
- 24 mag.pön rin.po.che
- 25 ter.chen.pö.yi bum.pa

PREPARATION:

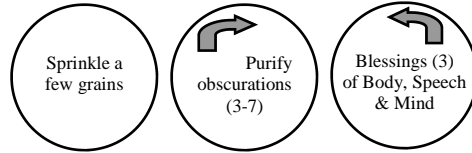

FIRST RING:

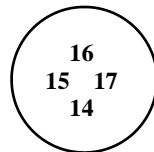
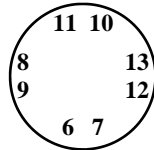

SECOND RING:

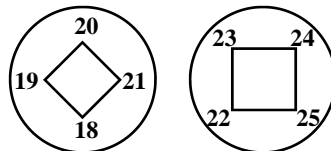

SHORT MANDALA OFFERING

sa.zhi pö.kyi j'uk.shing me.tok tram
ri.rap ling.zhi nyi.dä gyän.pa di
sang.gyã zhing.d'u mik.te ül.war gyi
dro.kün nam.dak zhing.la chö.par.shok

THANKSGIVING

je.tsun la.me ku.tse rab.ten ching
nam.kar trin.le chog.chur gye.pa dang
lo.sang ten.pe dron.me sa.sum gyi
dro.we mun.sel tag.tu ne.gyur chig

IDAM GURU RATNA MANDALA KAM
NIRYA TAYAMI

DEDICATION PRAYERS

THANKSGIVING MANDALA

Leader only:

Zhin.kham bur.wa zhu

The whole group:

OM vajra bhumi AH HUM

wang.chen ser.gyi sa.zhi

OM vajra rekhe AH HUM

chi chag.ri kor.yug.gi

kor.wai u.su

ri gyäl.po ri.rab

shar lu.pag.po

lho dzam.bu.ling

nub ba.lang.chö

jang dra.mi.nyen

lu.dang lu.pag

nga.yab.dang nga.yab zhen

yo.dang dang.lam chog.dro

dra.mi.nyan.dang

dra.mi.nyan gyi.da

rin.po.che ri.wo

pag sam.gyi shing

do.jöi ba

ma.mo.pa.yi lo.tog

kor.lo rin.po.che

nor.bu rin.po.che

tsun.mo rin.po.che

lön.po rin.po.che

lang.po rin.po.che

ta.chog rin.po.che

mag.pön rin.po.che

ter.chen.pö.yi bum.pa

geg.ma treng.wa.ma

lu.ma gar.ma

me.tog.ma dug.po.ma

nang.säl.ma dri.chab.ma

nyi.ma da.wa

rin.po.che dug

chog.la nam.par

gyäl.wa gyal.tsen

u.su lha.dang mi.yi päl.jor

pun.sum tsog.pa

ma.tsang.wa me.pa

tzang.zhing yi.du ong.wa di.dag

dring.chen tsa.wa

dang.gyur.par

che.pay päl.den la.ma dam.pa

nam.dang kyä.par du.yang

yun.gyi ge.wai shin.ye chen.po

zhal.nga.ne teg.pa chen.po

sung.cho zab.mo zhu.wai yul.du

zhing.kam ul.war gyio

tug.je dro.we dön.du zhe.su söl

zhe.ne dag.sog dro.wa

mar.gyur nam.ke ta.dang

nyam.pe sem.chan tam.che.la

tug.tse.wa chen.pö go.ne

jin.gyi lab.tu söl

26&27 geg.ma/ treng.wa.ma

28&29 lu.ma/ gar.ma

30&31 me.tog.ma/ dug.po.ma

32&33 nang.säl.ma/ dri.chab.ma

34&35 nyi.ma da.wa

36 rin.po.che dug

37 chog.la nam.par

gyäl.wa gyal.tsen

38 u.su lha.dang mi.yi päl.jor

pun.sum tsog.pa

ma.tsang.wa me.pa

tzang.zhing yi.du ong.wa

di.dag dring.chen tsa.wa

dang.gyur.par

che.pay päl.den la.ma dam.pa

nam.dang *kyä.par du.yang*

jet.sün.ma pa.ma dröl.mäi

lha.tsog kor.dang chä.pa nam.la

zhing.kam ul.war gyio

tug.je dro.we dön.du zhe.su söl

zhe.ne dag.sog dro.wa

mar.gyur nam.ke

ta.dang nyam.pe

sem.chan tam.che.la

tug.tse.wa chen.pö go.ne

jin.gyi lab.tu söl

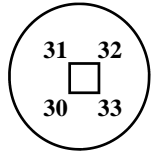
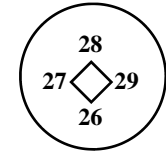

TOP RING:

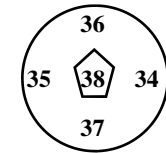

TARA LONG MANDALA OFFERING

	OM vajra bhumi AH HUM Wang.chen ser.gyi sa.zhi	OM vajra ground AH HUM, Mighty golden ground.
	OM vajra rekhe AH HUM chi chag.ri kor.yug.gi	OM vajra fence AH HUM, The iron fence around the edge.
1	kor.wai u.su ri gyäl.po ri.rab	In the centre is Mount Meru, The king of Mountains,
2	shar lu.pag.po	In the east the continent of Lupapo,
3	lho dzam.bu.ling	In the south Dzambuling,
4	nub ba.lang.chö	In the west Balangcho,
5	jang dra.mi.nyen	In the north Draminyan.
6&7	lu.dang lu.pag	In the east are the sub-continents Lu
8&9	nga.yab.dang nga.yab zhen	and Lupang, in the south Ngayab and
10&11	yo.dang dang.lam chog.dro	Nyayab-zhan, in the west Yodan and
12	dra.mi.nyan.dang	Lamchog-dro, in the north
13	dra.mi.nyan gyi.da	Draminyan and Draminyan-gyida.
14	rin.po.che ri.wo	Here are the precious mountain,
15	pag sam.gyi shing	The wish-granting tree,
16	do.jö ba	The wish-fulfilling-cow,
17	ma.mo.pa.yi lo.tog	The unploughed harvest.
18	kor.lo rin.po.che	Here is the precious wheel,
19	nor.bu rin.po.che	The precious jewel,
20	tsun.mo rin.po.che	The precious queen,
21	lön.po rin.po.che	The precious minister,
22	lang.po rin.po.che	The precious elephant,
23	ta.chog rin.po.che	The precious horse,
24	mag.pön rin.po.che	The precious general,
25	ter.chen.pö.yi bum.pa	The great treasure vase.
26	geg.ma	Here are the goddess of beauty,
27	treng.wa.ma	The goddess of garlands,
28	lu.ma	The goddess of song,
29	gar.ma	The goddess of dance,
30	me.tog.ma	The goddess of flowers,

SHORT MANDALA OFFERING

sa.zhi pö.kyi j'uk.shing me.tok tram
ri.rap ling.zhi nyi.dä gyän.pa di
sang.gyä zhing.d'u mik.te ül.war gyi
dro.kün nam.dak zhing.la chö.par.shok

REQUESTING TO TEACH

je.tsun lama dam.pa ky.nam kyi
cho.ku ka.la kyen.tse trin.trig ne
ji.tar tsam.pe dul.je dzim.ma la
zab.gye cho.kyi char.pa bab.tu sol

IDAM GURU RATNA MANDALA KAM
NIRYA TAYAMI

REFUGE AND BODHICITTA

Sang.gye cho.dang tsog.kyi chog.nam la
Jang.chub bar.du dag.ni kyab.su chi
Dag.gyi cho.nyen gyi.pay so.nam kyi
Dro.la pan.chir sang.gye drub.par shog

REQUESTING MANDALA

Leader only:

Zhin.kham bur.wa zhu

The whole group:

OM vajra bhumi AH HUM

wang.chen ser.gyi sa.zhi

OM vajra rekhe AH HUM

chi chag.ri kor.yug.gi

kor.wai u.su

ri gyäl.po ri.rab

shar lu.pag.po

lho dzam.bu.ling

nub ba.lang.chö

jang dra.mi.nyen

lu.dang lu.pag

nga.yab.dang nga.yab.zhen

yo.dang dang.lam chog.dro

dra.mi.nyan.dang

dra.mi.nyan.gyi.da

rin.po.che ri.wo

pag sam.gyi shing

do.jöi ba

ma.mo.pa.yi lo.tog

kor.lo rin.po.che

nor.bu rin.po.che

tsun.mo rin.po.che

lön.po rin.po.che

lang.po rin.po.che

ta.chog rin.po.che

mag.pön rin.po.che

ter.chen.pö.yi bum.pa

geg.ma treng.wa.ma

lu.ma gar.ma

me.tog.ma dug.po.ma

nang.säl.ma dri.chab.ma

nyi.ma da.wa

rin.po.che dug

chog.la nam.par

gyäl.wa gyal.tsen

u.su lha.dang mi.yi päl.jor

pun.sum tsog.pa

ma.tsang.wa me.pa

tzang.zhing yi.du ong.wa di.dag

dring.chen tsa.wa

dang.gyur.par

che.pay päl.den la.ma dam.pa

nam.dang kyä.par du.yang

yun.gyi ge.wai shin.ye chen.po

zhal.nga.ne teg.pa chen.po

sung.cho zab.mo zhu.wai yul.du

zhing.kam ul.war gyio

tug.je dro.we dön.du zhe.su söl

zhe.ne dag.sog dro.wa

mar.gyur nam.ke ta.dang

nyam.pe sem.chan tam.che.la

tug.tse.wa chen.pö go.ne

jin.gyi lab.tu söl

31 dug.po.ma

32 nang.säl.ma

33 dri.chab.ma

34&35 nyi.ma da.wa

36 rin.po.che dug

37 chog.la nam.par

gyäl.wa gyal.tsen

38 u.su lha.dang mi.yi

päl.jor pun.sum tsog.pa

ma.tsang.wa me.pa

tzang.zhing yi.du ong.wa

di.dag dring.chen tsa.wa

dang.gyur.par

che.pay päl.den la.ma dam.pa

nam.dang *kyä.par du.yang*

jet.sün.ma pa.ma dröl.mäi

lha.tsog kor.dang chü.pa

nam.la

zhing.kam ul.war gyio

tug.je dro.we dön.du

zhe.su söl

zhe.ne dag.sog dro.wa

mar.gyur nam.ke

ta.dang nyam.pe

sem.chan tam.che.la

tug.tse.wa chen.pö go.ne

jin.gyi lab.tu söl

The goddess of incense,

The goddess of light,

The goddess of perfume.

Here are the sun, the moon,

The precious parasol,

The banner of victory in all directions.

In the centre are the most perfect riches of gods and humans, with nothing missing, pure and delightful.

To my glorious, holy and most kind root Guru, the lineage Gurus, *and in particular to Arya Tara and her entire assembly,*

I offer these as a Buddha-field.

Please accept them with compassion, for the sake of migrating beings.

Having accepted them, please bestow on me and on mother sentient beings, abiding as far as the limits of space, your inspiration with loving compassion.

SHORT MANDALA OFFERING

sa.zhi pö.kyi j'uk.shing
me.tok tram
ri.rap ling.zhi nyi.dä
gyän.pa di
sang.gyä zhing.d'u mik.te
ül.war gyi
dro.kün nam.dak zhing.la
chö.par.shok

This ground, anointed with perfume,
strewn with flowers, adorned with
Mount Meru, the four continents, the
sun and the moon. Imagined as a
Buddha land and offered to you; may
all beings enjoy this pure land.

INNER MANDALA OFFERING

da.gi cha.dang mong.sum
kye.pe.yul
dra.nyen bar.sum lu.dang
long.cho chay
pang.pa may.par bul.gyi
leg.zhe.nya
dug.sum. rang.sar drol.war
jin.gyi.lob

Please enjoy and bless me and all
sentient beings to be released from the
three poisonous minds, for I am
offering without attachment my body,
enemy, friend and stranger, and all
possessions which are the object of
my greed, ignorance and hatred.

SENDING OFF...

IDAM GURU RATNA MANDALA
KAM NIRYA TAYAMI

I send forth this jewelled mandala to
you precious gurus.

MANDALA INSERTS

INSERT FOR SHAKYAMUNI BUDDHA

che.pay päl.den la.ma dam.pa
nam.dang kyä.par du.yang
nyam.me shak.yai gyal.po
lha.tsog kor.dang chä.pa nam.la
zhing.kam ul.war gyio

To my glorious, holy and most kind
root Guru, the lineage gurus, and in
particular *to the Victor of the
Shakya clan, and the entire
assembly of deities*,
I offer these as a Buddha-field.

INSERT FOR GURU PUJA

che.pay päl.den la.ma dam.pa
nam.dang kyä.par du.yang
la.ma lo.zang tub.wang
dor.je chang chen.po lha.tsog
kor.dang chä.pa nam.la
zhing.kam ul.war gyio

To my glorious, holy and most kind
root Guru, the lineage gurus, and in
particular *to the great lama Tsong
Khapa, Buddha who is King of
Sages, Vajradhara, and the entire
assembly of deities*,
I offer these as a Buddha-field.

INSERT WITH A LAMA PRESENT

che.pay päl.den la.ma dam.pa
nam.dang kyä.par du.yang
yun.gyi ge-wai shin-ye chen.po
zhal nga.ne teg.pa chen.po
sung.cho zab.mo zhu.wai yul.du
zhing.kam ul.war gyio

To my glorious, holy and most kind
root Guru, the lineage gurus, and in
particular *[request suitable for any
lama and any occasion]*,
I offer these as a Buddha-field.

